



Breeze Fans EC/AC

Air circulation fans

The Breeze Fan moves extremely large amounts of air and is highly energy efficient.

The principle is to create a steady, light movement of air for the cooling effect in warmer temperatures and to direct the rising warm air to the floor at the height of the animals in colder periods. In addition the Breeze Fan reduces humidity and odours and creates a healthier environment for animals and humans.

Advantages

- Available in a range of diameters
- Variable speed control by means of frequency inverter and gear motor
- Several Breeze fans AC can be operated with just a single frequency inverter
- Stable aerofoil-shaped aluminium blades
- Quiet-running
- Improves animal welfare throughout the year
- Easy to assemble



Breeze Fan

Cows in particular, but also other animals such as pigs, poultry and horses, are sensitive to heat and develop stress symptoms. The continuous circulating air cooling throughout the building makes the whole stable to a comfort zone. Performance depressions due to heat stress are thus avoided. The environment and laying areas remain dry. The continuous air flow also helps against birds and insects. The special shape of the blades creates large cylindrical air streams that are directed to the ground. When the air flow hits the ground, it is directed to the nearest environment, so that a steady air flow is created everywhere in the animal area. This air moves sideways until it hits a wall, for example. Then it flows vertically upwards again. The greater the cylindrical air flow, the greater the air circulation and the resulting benefits.

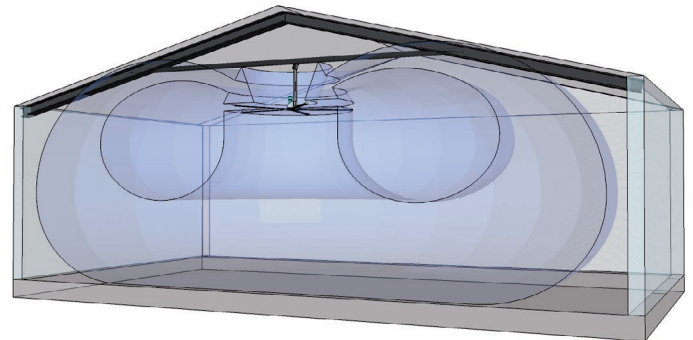

Simulation of air movement

Accessories



Frequency inverter



TempMan incl. temperature sensor



TPR position transmitter



Flex bracket

Breeze Fans

Air circulation fans

Installation table for Breeze Fan

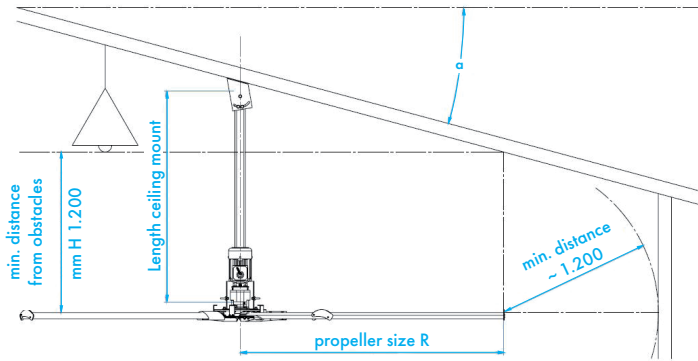

propeller size		roof slope a [°] (min – max)	
[m]	[m]	Short ceiling bracket (L=1.5m)	Long ceiling bracket (L=2.25m)
1.5	3	0 – 16	17 – 38
2.0	4	0 – 12	13 – 30
2.5	5	0 – 10	11 – 25
3.0	6	0 – 8	9 – 21
3.5	7	0 – 7	8 – 19

Technical data

		Ø 3 m	Ø 4 m	Ø 5 m	Ø 6 m	Ø 7 m
Number of blades				5		
Blade length (single)	[cm]	130	180	230	280	330
Fan capacity	[m ³ /h]	219,000	310,000	319,000	423,000	485,000
Noise level	[dBm]	55	53	51	50	48
Gear motor EC (230 V)	kW [HP]	1.1 (1.5)	1.1 (1.5)	1.1 (1.5)	1.5 (2.0)	1.5 (2.0)
Gear motor AC (400 V)		—	1.1 (1.5)	1.1 (1.5)	1.5 (2.0)	1.5 (2.0)
Total weight	kg	95	101	108	115	122
Max. Speed	RPM	140	100	80	70	55
Protectice class of electric motor				IP55		
Distance between Breeze Fans ¹	[m]	9 - 12	12 - 17	12 – 22	15 – 30	20 – 35

¹ depending on climate conditions

Wind Sensor for Breeze Fans EC

The wind sensor is used to record and evaluate wind speeds and generates a pulse sequence dependent on the speed of the wind turbine. This is evaluated in a downstream sensor relay. If wind speeds are too high, the Breeze Fan is automatically switched off to prevent damage to the device.

